

User Manual

Dual Folding Probe Thermometer

Codes: IRTLC750BT, IRTLC750NFC



Table of contents

- 1. Before working with the device 3
- 2. Overview 3
- 3. Safety instructions 4
- 4. Precautions 4
- 5. Device operation 5
 - 5.1 Switching on 5
 - 5.2 Switching off 5
 - 5.3 Penetration probe temperature measurements 5
 - 5.4 Infrared temperature measurements 5
 - 5.5 Logging modes 6
 - 5.5.1 AdHoc logging mode 6
 - 5.5.2 List logging mode 7
 - 5.6 Settings Menu 8
 - 5.6.1 Settings Menu Enter 8
 - 5.6.2 Settings Menu Operation 8
 - 5.6.3 Settings Menu Entries 9
- 6. What to do if... 10
- 7. Battery indicator and charge 10
- 8. Care and Maintenance 10
- 9. Disposal 11
- 10. Technical specifications * 12
- 11. Equipment 12
- 12. Standardize 13
- 13. Regulatory information 13
- 14. Service information 15
- 15. Manufacturer information 15

1. Before working with the device

- Please read the operating instructions carefully.
- Familiarize yourself with your new device, get to know all the functions and components, learn important details for commissioning and the handling the device and get tips for the case of a malfunction.
- By observing the operating instructions, you will also avoid damage to the device and the risk of your statutory rights of defects due to misuse. For damages resulting from failure to comply with this User manual, we assume no liability.
- Pay particular attention to the safety instructions!
- Keep this manual in a safe place!

2. Overview

The IRTLC750NFC and IRTLC750BT are both infrared and contact thermometers. You can choose between these two types of measurement at any time. While using them as an infrared thermometer, two integrated laser pointers help to aim at the desired measuring surface.

The model variant IRTLC750BT has a Bluetooth LE interface integrated for wireless data transmission. In addition, the device offers a USB interface for wired data transmission. The integrated battery can be charged via USB or using wireless charging technology.

In addition to the functions of the IRTLC750BT device, the model variant IRTLC750NFC has an NFC reader integrated with which NFC tags can be read.

- 1..... two laser pointers
- 2..... .Infrared lens
- 3..... Button 1 / Infrared measurement
- 4..... ..Button 2
- 5..... Button 3
- 6..... Display
- 7..... Penetration probe
- 8..... NFC reader antenna position
(on backside)

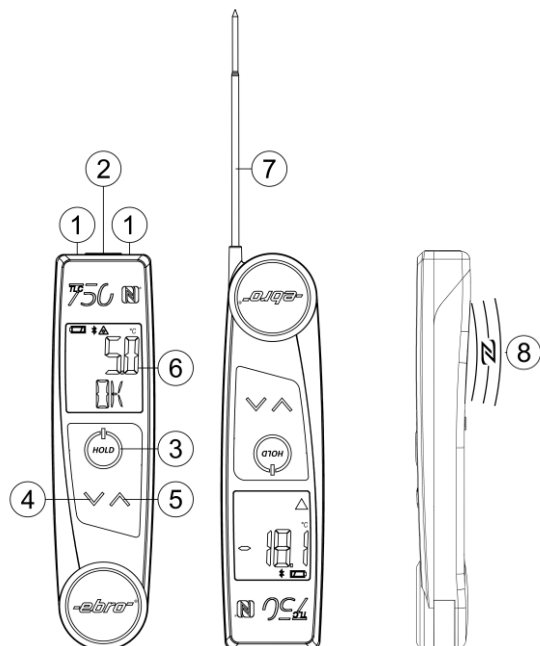

3. Safety instructions



The device is not suitable for children. Keep out of the reach of children!

Risk of injury!

There is a risk of injury when the probe needle is unfolded.

Risk of contamination! In case of injuries with the probe needle you could contract dangerous germs!

Burns!

After measuring high temperatures, the probe needle still is hot for some time.

Avoid over-tightening the penetration probe pivot. Overstressing the penetration probe may cause breakage.

Operate the device only within the specified parameters.



Warning of laser light!

Risk of injury to the eyes! Do not aim the laser directly or indirectly via reflective surfaces to the eyes.

4. Precautions

Protect the thermometer from the following influences:

- Strong electromagnetic fields e.g. induction heaters
- Static electricity
- Do not use on or near hot or very cold objects.

5. Device operation

5.1 Switching on

The device can be switched on by pressing  button or by unfolding the penetration probe. If penetration probe is folded, IRT measurement is active. Otherwise core temperature measurement is active.



When the device is switched on, the device waits for a Bluetooth connection and displays this with a flashing Bluetooth symbol. Once connected, the Bluetooth icon is permanently displayed.

5.2 Switching off



The device will switch off automatically after 1 minutes if in infrared mode, or after 10 minutes if in penetration probe mode. When the penetration probe is closed, the device will switch off immediately. The backlight switches off after 10 seconds of inactivity.

5.3 Penetration probe temperature measurements

The Penetration probe must be unfolded for this mode of operation. Position the probe needle where you want to measure the temperature. Wait until temperature has stabilized.

By pressing  button last measured temperature value is held until  is pressed again.









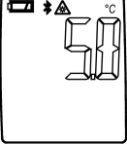

5.4 Infrared temperature measurements

The penetration sensor must be closed for this mode of operation. To take a reading with the infrared sensor, point the infrared lens at the point to be measured and press and hold the  button. Aim so that both laser points are on the object to be measured. The area whose temperature is measured is located between the two laser points. If  button is released the last measured value is held.

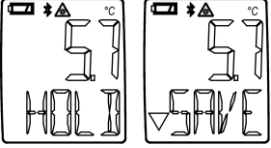
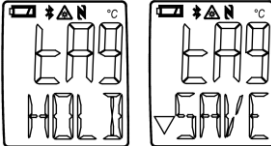
5.5 Logging modes





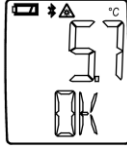
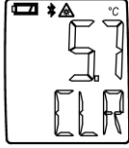
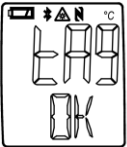
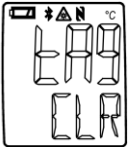



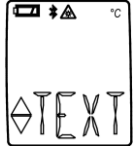

5.5.1 AdHoc logging mode

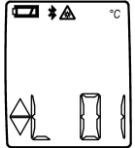
This mode offers real time measurement data transmission via a Bluetooth LE connection. In addition measurement values can be stored at internal storage memory for readout at a later time. The device has to be programmed by host software for this mode.

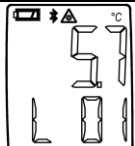
Step	Description	LCD display
1	<p>In infrared mode temperature measurements are taken while  button is pressed.</p> <p>In penetration probe mode temperature measurements are taken while no key is pressed.</p>	
2	<p>In infrared mode temperature value is held if  button is released. In this state device alternately shows "HOLD" and "SAVE".</p> <p>In penetration probe mode temperature measurement is held if  button is shortly pressed. In this state device alternately shows "HOLD" and "SAVE".</p> <p>If Bluetooth is connected measurement data is transferred via Bluetooth.</p> <p>Only available at IRTLC750NFC device:</p> <p>If  button is pressed down the internal NFC reader searches every time once for NFC tags.</p> <p>If a NFC tag was found device shows "TAG" and alternately "HOLD" and "SAVE".</p> <p>If Bluetooth is connected NFC tag data is transferred via Bluetooth.</p>	 
3	<p>To store measurement to internal storage memory  button has to be pressed. Device confirms with "OK".</p> <p>To discard measurement  button has to be pressed. Device confirms the memory with the display "CLR".</p> <p>Pressing  takes a new measurement.</p> <p>Only available at IRTLC750NFC device:</p> <p>To store NFC tag data to internal storage memory  button has to be pressed. Device confirms the memory storage executing with "OK".</p> <p>To discard NFC tag data  button has to be pressed. Devices confirms with "CLR".</p> <p>Pressing  takes a new measurement.</p>	   

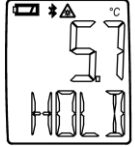
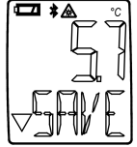
5.5.2 List logging mode

This operating mode offers a guided tour with display of the measuring locations. In addition measurement values can be stored at internal storage memory for readout at a later time. Device has to be programmed by host software with a tour list before list logging mode is active.

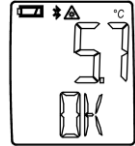
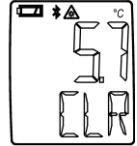

Step	Description	LCD display
1	After device is started the first location text is shown on LCD. This location texts are free programmable by host software.	
2	By use of  or  buttons it is possible to change measurement location	
3	<p>In infrared mode temperature measurements are taken while  button is pressed.</p> <p>In penetration probe mode temperature measurements are taken while no key is pressed</p>	
4	<p>In infrared mode temperature value is held if  button is released.</p> <p>In penetration probe mode temperature measurement is held if  button is shortly pressed. In this state display alternately shows "HOLD" and "SAVE".</p>	 
5	<p>To store measurement to internal storage memory  button has to be pressed. Device confirms with "OK". List location is automatically changed to next list location.</p> <p>To discard measurement  button has to be pressed. Device confirms with "CLR".</p> <p>Pressing  takes a new measurement.</p>	 

5.6 Settings Menu

5.6.1 Settings Menu Enter

When device is switched off: press  and  buttons and after that additionally  button for 3 seconds.



5.6.2 Settings Menu Operation

If menu is entered it is possible to change current displayed menu entry by the  and  Buttons.

When  button is pressed next menu entry is displayed.

If no button is pressed for 3 seconds next menu entry is displayed. After last menu entry is displayed device starts measure mode.

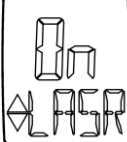
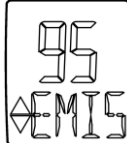
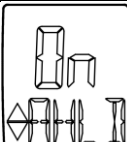
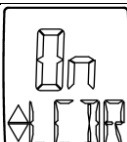
5.6.3 Settings Menu Entries

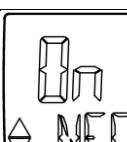

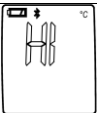
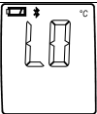

Menu entry	LCD display
<p>"UNIT" Temperature unit [°C / °F] Default: °C</p>	
<p>"LASR" IRT Laser [ON / OFF] Default: ON</p>	
<p>"EMIS" IRT Emissivity [10..100] Default: 95</p>	
<p>"AHLI" Auto Hold function for penetration probe [ON / OFF] Default: ON</p>	
<p>"LCDR" LCD rotation setting [ON / OFF] Default: ON</p>	
<p>"BLKL" Backlight [ON / OFF] Default: ON</p>	
<p>Only available at IRTLC750NFC device:</p> <p>"NFC" NFC reader functionality [ON / OFF] Default: ON</p>	

6. What to do if...

Failure	Cause, Troubleshooting
	Temperature to be measured above + 250 ° C.
	Temperature to be measured below -50 ° C.
Device can not be switched on:	Battery empty. Charge the battery. If still not working with charged battery, contact the ebro service team

7. Battery indicator and charge

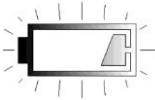
The battery of the device can be charged via the USB port or wirelessly using the base station IF 750 or the charger CS 750.

Charging indicator	Description
	Battery fully charged Charging completed
	Battery partially discharged
	Battery almost empty
	Charging active

8. Care and Maintenance

Clean the lens

Blow loose particles with clean compressed air. Then carefully remove impurities with a soft brush. Gently wipe the surface with a damp cotton ball. Moisten the cotton ball only with clear water! DO NOT use solvents to clean the lens.

Clean housing

Clean the device with soap solution and a damp cloth. DO NOT immerse the device in the water. DO NOT use solvents such as acetone!

9. Disposal



If the device has become unusable, it must be disposed of in a way that is appropriate for the environment. Do not dispose of the device with household waste, but do it according to the specific national requirements legislation regarding recycling.

10. Technical specifications *

Measuring Range	-50 ... +250 °C
Accuracy (at +23°C ± 1°C)	Infrared: -50° C ... -30.1 °C ±4.0 °C -30 °C ... -18.1 °C ±2.5 °C -18 °C ... -0.1 °C ±1.5 °C 0 °C ... +64.9 °C ±1.0 °C 65 °C ... +250 °C ±2.0 °C or 2 % (the larger value applies) Penetration probe: ± 0.5 °C in a measuring range -30.0 ... +99 °C; otherwise ±1.0 °C or 1 % (the larger value applies)
Sample rate	1s
Resolution	0.1 °C
Emissivity	0,95, adjustable
IR optics	8:1
Laser	Dual Laser to display the measuring surface
Working temperature:	Measuring: -20°C ... +50 °C Charging: 0 ... +40°C
Storage temperature	-30 ... +70 °C (without battery pack) -20 ... +55 °C (with battery pack)
Weight	130 g
Dimensions	L x B x T 169.5 x 44 x 23 mm
Protection class	IP65
Battery operating time	typical 8h at continuous use
Battery type	3.7V Lithium Polymer
Battery charging	USB Requirements for the external Power supply unit: -Limited Power Source according IEC60950-1 or PS2 classified IEC62368-1 - Short-circuit current < 8A Wireless (WPT) by means of IF 750 or CS 750
Battery recharge time	typically 3h
Interfaces	USB 2.0 (USB C) Bluetooth 4.0 Low Energy (BLE) IRTLC750NFC: NFC Reader 13.56 MHz (ISO 14443 A)
Temperature measurements storage size	200
List storage size	100
NFC tag data storage size	IRTLC750NFC: 100

* technical changes reserved

12. Standards

This product meets the requirements of the standard DIN EN 13485

Suitability: S, T (storage, transport)

Environment: E

Accuracy class: 0.5

According to DIN EN 13485 is a regular check and calibration of the meter necessary.

13. Regulatory information

General



This device is tested according to ETSI EN.
It meets the requirements of ETSI EN

Radio approvals

RED

EN 61000-4-2
EN 61000-4-3
EN 61326-1:2021
EN 62368-1:2014
EN 62311
ETSI EN 300 330
ETSI EN 303 ETSI EN 300 328 V 2.2.2
ETSI EN 301 489-1 V 2.2.3
EN 301 489-3
EN 301 489-17

LVD

62368-1:2014

FCC

FCC ID: VQ5-TLC750NFC

This device contains FCC ID: QQQBGM113

This device complies with Part 15 of the FCC Rules. Operation is subject to the following two conditions:

- (1) this device may not cause harmful interference, and
- (2) this device must accept any interference received, including interference that may cause undesired operation.

The Federal Communications Commission (FCC) warns the users that changes or modifications to the unit not expressly approved by the party responsible for compliance could void the user's authority to operate the equipment.

FCC §15.105 (b):

Note: This equipment has been tested and found to comply with the limits for a Class B digital device, pursuant to part 15 of the FCC Rules. These limits are designed to provide reason-able protection against harmful interference in a residential installation. This equipment generates, uses and can radiate radio frequency energy and, if not installed and used in accordance with the instructions, may cause harmful interference to radio communications. However, there is no guarantee that interference will not occur in a particular installation. If this equipment does cause harmful interference to radio or television reception, which can be deter-mined by turning the equipment off and on, the user is encouraged to try to correct the interference by one or more of the following measures:

IRTLC750BT / IRTLC750NFC
Operation Manual

- Reorient or relocate the receiving antenna.
- Increase the separation between the equipment and receiver.
- Connect the equipment into an outlet on a circuit different from that to which the Receiver is connected.
- Consult the dealer or an experienced radio/TV technician for help.

IC

IC: 7412A-TLC750NFC

This device contains IC: 5123A-BGM113

This device complies with Industry Canada's license-exempt RSSs.
Operation is subject to the following two conditions:

- (1) This device may not cause interference; and
- (2) This device must accept any interference, including interference that may cause undesired operation of the device.

Le présent appareil est conforme aux CNR d'Industrie Canada applicables aux appareils radio exempts de licence. L'exploitation est autorisée aux deux conditions suivantes:

- 1) l'appareil ne doit pas produire de brouillage;
- 2) l'utilisateur de l'appareil doit accepter tout brouillage radioélectrique subi, même si le brouillage est susceptible d'en compromettre le fonctionnement.

14. Service information

Rynor House,
Farthing Road,
Ipswich,
IP1 5AP
Telephone: +44 (0)1473461800
Website: www.klipspringer.com
E-Mail: sales@klipspringer.com

15. Manufacturer information

Rynor House,
Farthing Road,
Ipswich,
IP1 5AP